

TECHNICAL DATA

Dimensions

Exterior Dimensions (WxDxH)	52" x 32.25" x 25.5"
Interior Dimensions (WxDxH)	40.25" x 28" x 17"
Net Volume (cu. ft.)	
Gross Weight	300lbs
Packaging Dimensions (WxDxH)	55" x 35" x 29"
Electrical Cord Length	
Capacity	9.9 cu. ft.
Pans	6 - 1/6

Construction

Exterior Material	Stainless Steel
Interior Material	Stainless Steel
Insulation Material	
Shelf Material	
Shelf Load Capacity	

Cooling

Temperature Range	33° - 40° F
Refrigerant	R290
Maximum Ambient Temp	90° F
Maximum Humidity	65%
Defrosting	Automatic
Cooling System	
Temperature Display	Digital
Temperature Controller	H/P
H/P	1/6

Electrical

Voltage	115/60/1
Amps	4.6



Intertek

COMPLIES WITH ANSI/NSF 7
FOR FOOD SERVICE

PLAN VIEW

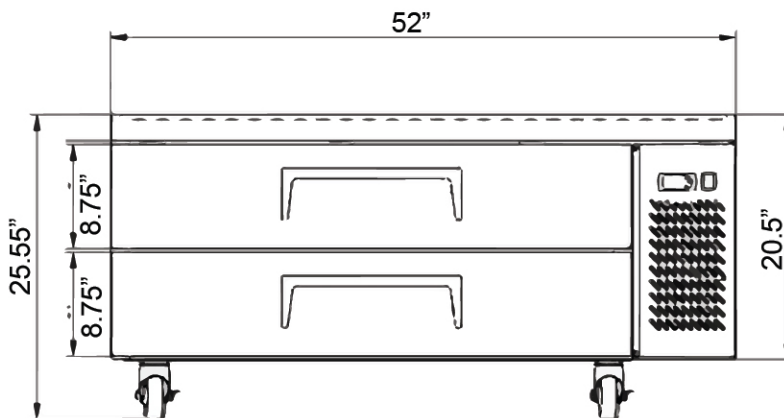

Front View

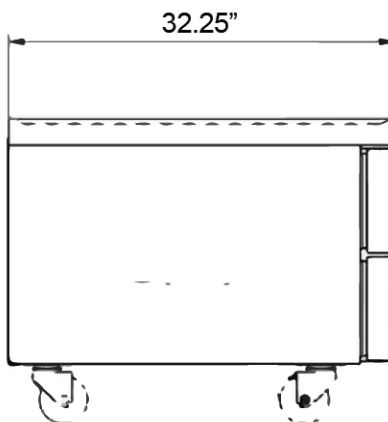

Side View

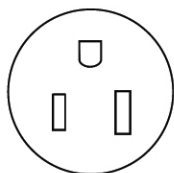

NEMA 5-15P

SCB-52

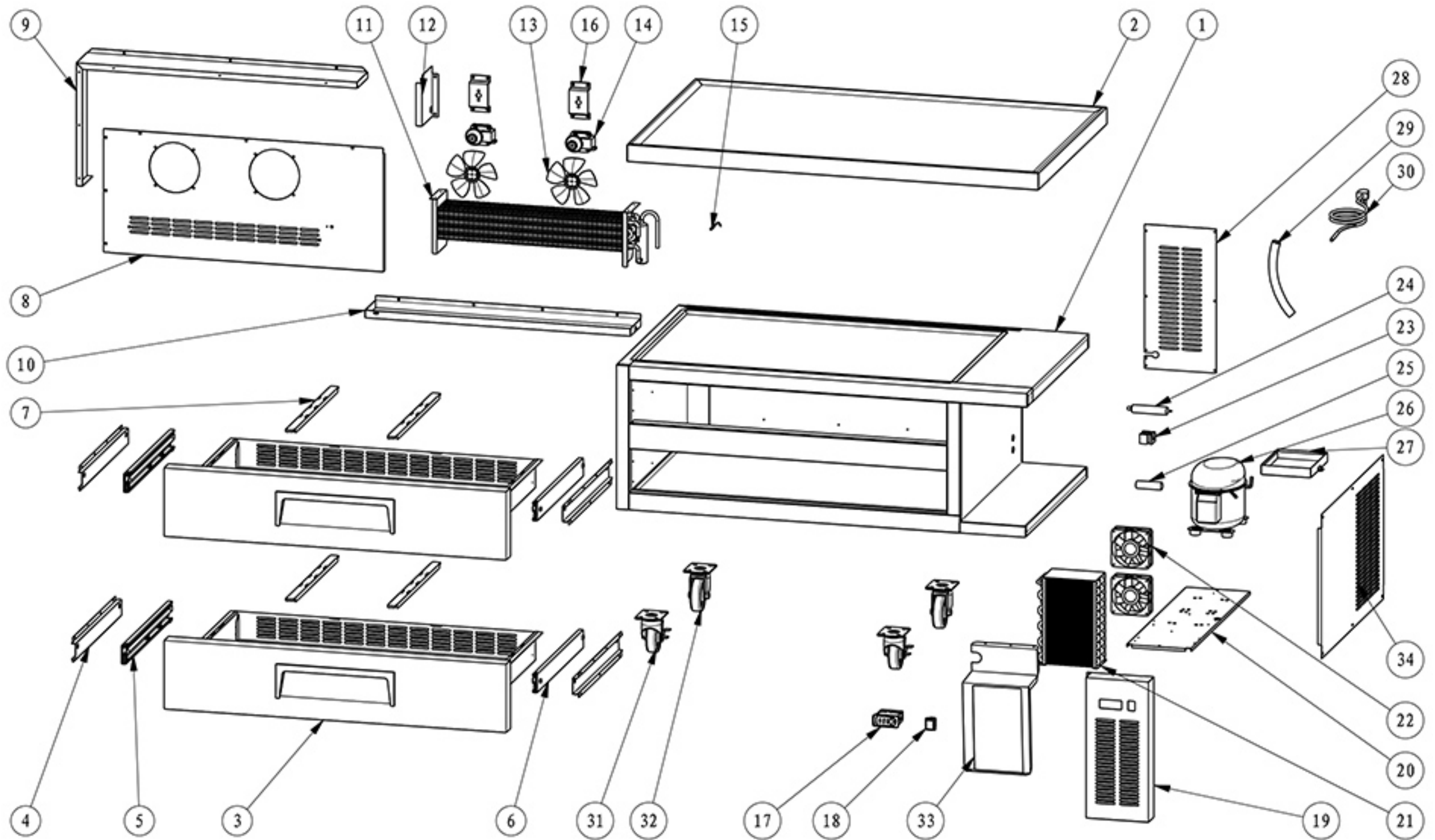

NO.	Part Name	Factory Part NO.	QTY
1	CABINET		1
2	TOP BOARD		1
3	DRAWER		2
4	HANGIN SHEET FOR DRAWER		4
5	DRAWER LEFT SLIDE		2
6	DRAWER RIGHT SLIDE		2
7	PAN BRACKET		2
8	EVAPORATOR COVER		1
9	EVAPORATOR COVER PLATE		1
10	INNER DRAIN PAN		1
11	EVAPORATOR	17405040594	1
12	AIR GUIDE SHEET		1
13	BLADE OF EVAPORATOR FAN MOTOR	16381737612	2
14	EVAPORATOR FAN MOTOR	22752520015	2
15	TEMPERATURE SENSOR OF CABINET INSIDE	17649490016	1
16	EVAPORATOR FAN MOTOR HOLDER		2
17	THERMOSTAT	17505110100	1
18	POWER SWITCH	17749211297	1
19	CONTROL PANEL		1
20	COMPRESSOR UNIT INSTALLATION BOARD		1
21	CONDENSER	17304110151	1
22	CONDENSER FAN MOTOR	1003001114715	2
23	FILTER FIXER	16369690257	1
24	FILTER	17111250145	1
25	START CAPACITOR		1
26	COMPRESSOR	17202100037	1
27	OUTER DRAIN PAN	16316130005	1
28	DRAIN HOSE	15809080016	1
29	BACK GRILL		1
30	POWER CORD	17664640051	1
31	4" CASTOR WITH BRAKE	12533110012	2
32	4" CASTOR	12533110013	2
33	CONDENSER AIR GUIDE SHEET		1
34	AIR DUCT		1