



SST-48 2 DOOR SANDWICH/SALAD PREP REFRIGERATOR

UNITS MANUFACTURED PRIOR 10-1-18
 INCLUDE 1 YEAR PARTS + LABOR / 5 YEAR COMPRESSOR WARRANTY

UNITS MANUFACTURED AFTER 10-1-18
 INCLUDE 2 YEAR PARTS + LABOR / 5 YEAR COMPRESSOR WARRANTY

Dimensions

Exterior Dimensions (WxDxH)	46.75" x 29.5" x 42.5"
Interior Dimensions Top (WxDxH)	42.5" x 13.5" x 8.5"
Interior Dimensions Bottom (WxDxH)	42.75" x 19.5" x 24"
Cutting Board Dimensions (WxDxH)	46.5" x 10.5" x .75"
Net Volume (cu. ft.)	9.75 cu. ft.
Gross Weight	360 lbs
Packaging Dimensions (WxDxH)	51" x 34" x 46.5"
Electrical Cord Length	84"

Cooling

Temperature Range	32° - 40° F
Refrigerant	R134a
Maximum Ambient Temperature Rating	100.4° F
Defrosting	Automatic
Temperature Display	Yes
Temperature Controller	Digital
H/P	1/3

Construction

Exterior Material	430 series stainless steel
Interior Material	304 series stainless steel
Insulation Material	Foamed in place polyurethane
Shelf Material	Plastic coated steel
Shelf Load Capacity	90 lbs

*Does not include pans

Electrical

Voltage	120
Amps	6.5
Hz	60
Phase	1

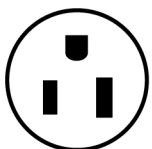
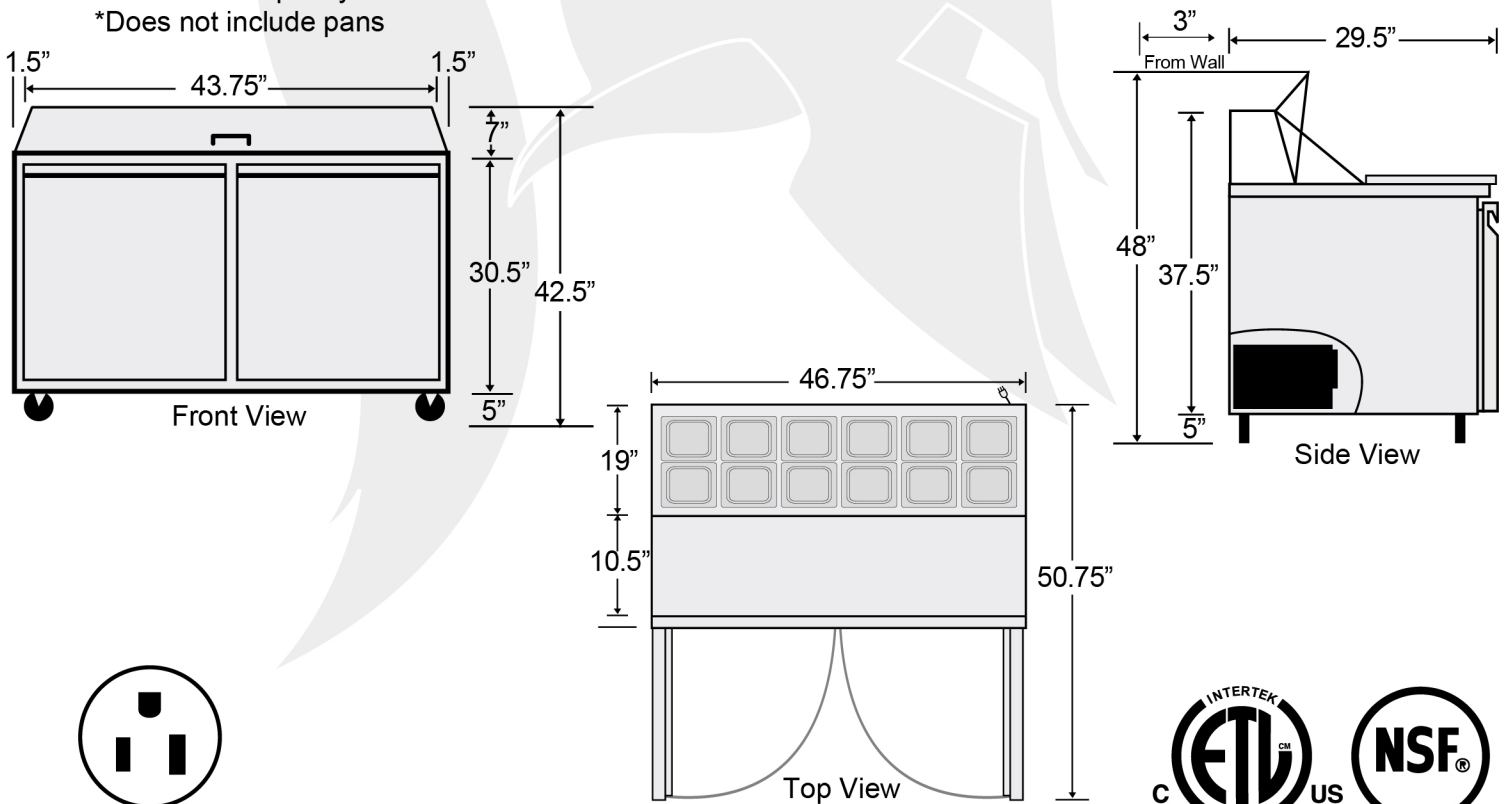

NEMA 5-15P

